

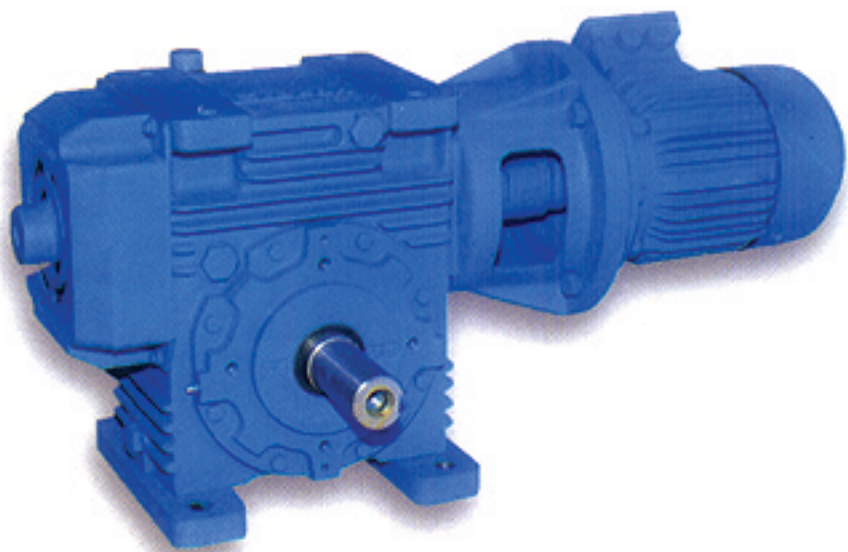

ELECON SUPER SERIES IN WORM GEAR UNITS



ELECON 

Always a step ahead in technology



Ever since Elecon's inception 48 years ago, they have strived to reach new frontiers of technical excellence. From a modest start in manufacturing material handling equipment namely ELEVATORS & CONVEYORS in 1951, Elecon graduated to the manufacture of gear boxes (initially for captive use) in 1963. Today, Elecon's name become synonymous with high quality gear and material handling equipment in India.

Elecon had set up a separate Gear Division in 1976. This division has a capacity of producing more than 25,000 gear unit yearly, out of which 90% share for worm speed reduction gear units and remaining share in helical speed reduction gear unit. The gear units are working satisfactorily in cement, chemical, plastic, paper, power generation, sugar, textile, thermal plant industries.

Elecon have a wide range of worm, parallel shaft and right angle helical – spiral bevel speed reduction gear units.

Elecon have many firsts to their credit. In the eighties, they were the first to introduce case-hardened and ground gear technology in India and the modular design concept for gear manufacture in India, as a result of which economical mass production and comprehensive maintenance of component stocks were made possible.

The latest additions to their production line are planetary gear boxes for marine and other applications which have already been delivered for use on the off-shore patrol vessels of the Indian Coast Guard. These are very compact, high precision gear boxes, capable of transmitting up to 23,000 KW of power.

For a forward-looking organisation like Elecon, modernisation is the watchword. That is precisely why they continuously update their production technology through frequent capital and infrastructural investments. Elecon have geared themselves for tomorrow by setting up one of the largest EDP centres in the Indian Engineering Industry. More than 85% of their machinery is computer controlled, ensuring a high degree of precision in the manufacture, design and testing of gear components. Apart from a large concentration of computerised numerically controlled (CNC) machines, they have flexible machining systems, a battery of modern quality control equipments for checking gear component's various parameters and geometry, on-line computerised inventory control, production planning and execution programmes. All this has resulted in Elecon's Gear Division being the most modern in the country – a fact that is unanimously acknowledged throughout the industry. Just as it is acknowledged by clients that Elecon, despite their stature and focus on modernisation, have not lost sight of their primary goal - customer satisfaction.

ISO – 9001 for Elecon Gear Division

In November 1994, the RW – TUV Germany has accredited that Elecon Gear Division Quality Management System confirms to the internationally accepted ISO 9001 standards. This certificate covers Quality Assurance in Design and Development, Production, Installation and Service of mechanical transmission products like Worm, Helical and special gear units, Fluid , Geared and Flexible couplings and Accessories.

ELECON 

* **MODEL & TYPE : WORM GEARED MOTOR – SWM**

SIZES : $1 \frac{3}{4}$, $2 \frac{1}{4}$, 3, 4

RATIO : Min. 5 : 1 to Max. 70 : 1

OTHER SIZES CAN BE SUPPLIED ON REQUEST.

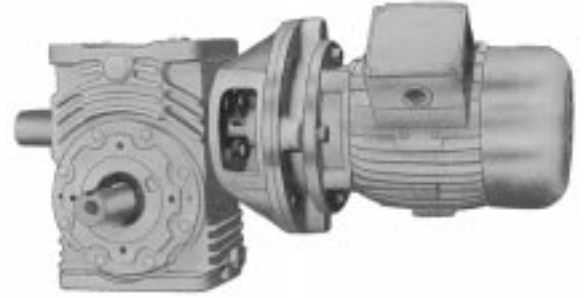

SWM

*** DOUBLE REDUCTION UNITS (HELICAL/WORM)**

MODEL & TYPE : Combination with First pair helical gear unit and Second pair with worm gear unit.

- Underdriven (HSFU)
- Overdriven (HSFO)
- Vertical output shaft up/down (HSFV)
- Hollow output shaft (HSSM)

SIZES : 7, 8, 9, 10.5, 12, 14

RATIO : Max. 440 : 1

Power Capacity to 70 KW.

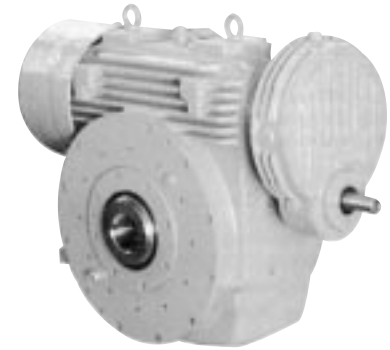

HSSM

*** Heavy Duty Stirrer Units**

Heavy Duty stirrer unit incorporates an extended bearing housing to accommodate a larger bottom bearing and increased shaft size, there by enhancing the unit capacity to absorb the high bending loads imposed during stirrer applications. This gear unit is compact with facility of top mounted pivoted platform where electric motor can be directly mounted above the gear unit using belt tensioning device.

MODEL & TYPE : SNU-CVDM

SIZES : 4, 5, 6, 7, 8, 9, 10.5

MODEL & TYPE : CVDM

SIZES : 12, 14, 17

RATIO : Min. 5 : 1 to Max, 70 : 1

Power Capacity to 350 KW

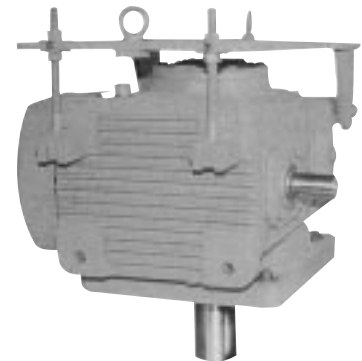

SNU-CVDM/CVDM

*** Cooling Tower Fan Drive Gear Unit**

Cooling Tower Fan Drive Gear Unit incorporates an extended top bearing housing to accommodate the larger wheel shaft bearing.

Length of the output shaft extension are manufactured to client's requirements and to suit fan hub mounting.

Lubrication is entirely contained by splash and lower bearing dip in the oil bath while oil is pumped to the top wheel shaft bearing by mean of a built in plunger mechanism. All exposed parts other than the extensions are applied with corrosion resistant paint.

MODEL & TYPE : SNU-CTU

SIZES : 4, 5, 6, 7, 8, 9, 10.5

MODEL & TYPE : CTU

SIZES : 12, 14, 17

RATIO : Min. 5 : 1 to Max. 70 : 1

Power Capacity : 350 KW



SNU-CTU/CTU



SUPER SERIES IN WORM GEAR UNITS

SPECIFICATIONS

GENERAL

Elecon single reduction gear units are the result of many years of experience. Completely re-designed gear case with liberal ribbing increases heat dissipating area, streamlined sump carrying more oil and larger capacity of fan enhance the thermal rating of the gearbox. All this means that the continuous load carrying capacity is increased without substantial rise in temperature.

No more opening of gearbox for hand changing, just replace the fan and fancowl from one end to other end of worm shaft.

DESIGN STANDARDS

Wherever applicable, British as well as Indian standards are used. Worm conforms to casehardening alloy steel, worm wheel conforms to phosphor-bronze PB2-C as per British Standard B.S. 1400, while gear case conforms to C. I. grade FG 220 and for heavy duty FG 250, Indian Standard I.S. 210.

GEAR CASE

Gear case is of streamlined design, rugged in construction, made of close-grain cast iron. It is completely oil-tight, dust-proof and capable of being installed in the open without a separate cover. The faces and bores are accurately bored and machined on latest precision machines to ensure perfect alignment and interchangeability.

WORM/WORM WHEEL

The worm is made of case-hardening alloy steel, carburised, ground and polished and is integral with the shaft. Bearing journals are accurately ground. Worm wheel is made of centrifugally cast phosphor-bronze rims, shrink fitted and brazed with C.I. centres.

Worms are generated on special-purpose worm milling machines, gas carburised and ground on automatic work grinders.

Worm wheels are hobbled on precision hobbing machines with high accuracy hobs. Each and every wheel is checked to match with the master worms to ensure complete interchangeability.

Right-hand threads are provided, unless otherwise specified.

BEARINGS

The worms and worm wheels are supported on ball or roller anti-friction bearings of ample margin of safety to allow adequate journal as well as thrust loads. Overhung loads arising out of sprocket or pinion drive are generally permissible because the gear case and bearings are

designed for this duty. However, complete details should be given to us for confirmation. In cases of heavy overhung loads, an extra roller bearing can be provided.

WHEEL SHAFT

The wheel shaft is made of high tensile carbon steel. It is of large diameter to carry the torsional as well as bending loads which may be induced by overhung drives.

LUBRICATION

Lubrication to gears and bearings is by splash of oil from the sump. Thus, no special care is required except for the occasional topping up of the oil to the required level. A large oil filler-cum-breather and inspection cover is provided together with a drain plug and ventilator. Neoprene lip-type oil seals are fitted on input and output shaft.

For very low input speed below 50 rpm. and heavy loads in sizes larger than 14" size forced lubrication is required. In such cases Elecon must be consulted.

COOLING

Air cooling is effected by means of standard polypropylene or metal fans which direct a continuous flow of air over the ribbed surface of the gear unit. The fan is designed to operate in both direction of rotation, and is so arranged in conjunction with the ribbing on the gear unit as to allow maximum heat dissipation.

HOLDBACK

Elecon Sprag type holdback can be fitted on all sizes of gears to prevent reverse rotation. In cases where holdback is required, the direction of rotation of the shaft should be mentioned.

POWER RATINGS

The ratings indicated in the catalogue holds good for 12 hours of continuous running under uniform load being driven by electric motor. They give minimum gear life of 26,000 hours, subject to limitation of maximum oil temperature of 100°C under full load, 20°C ambient.

OVERLOADS

All the components of the reduction gears are so designed that they can withstand.

- * 100 per cent overload for 15 seconds
- * 50 per cent overload for one minute
- * 40 per cent overload for 30 minutes and
- * 25 per cent overload for two hours.

Super NU Series MODULAR WORM GEAR UNIVERSAL MOUNTING

Further to successful launching of ELECON 'NU' Modular worm gearboxes, "SUPER NU" series is one step ahead in WORM GEAR TECHNOLOGY.

A combination of present-day concepts, analytical calculations with the help of CAD (Computer Aided Design) carried out on single part use of very latest CNC machine tools plus systematic checks on materials and workmanship, give this series of gearboxes a marked degree of reliability.

Single piece universal casing having flanges top and bottom side and also provision for a supporting flange make it possible to have the universal mounting positions for gearboxes such as underdriven, overdriven and vertical. The internal components are, therefore, interchangeable for all the mounting positions.

Quick change of mounting positions from underdriven to overdriven and vice versa merely by putting the unit upside down and replacing the positions of drain plug, breather plug and oil level indicator.

Comprehensive maintenance of stock and faster delivery can be achieved due to adoption of interchangeably principle. Robust compact and streamlined design with ample thermal capacities.

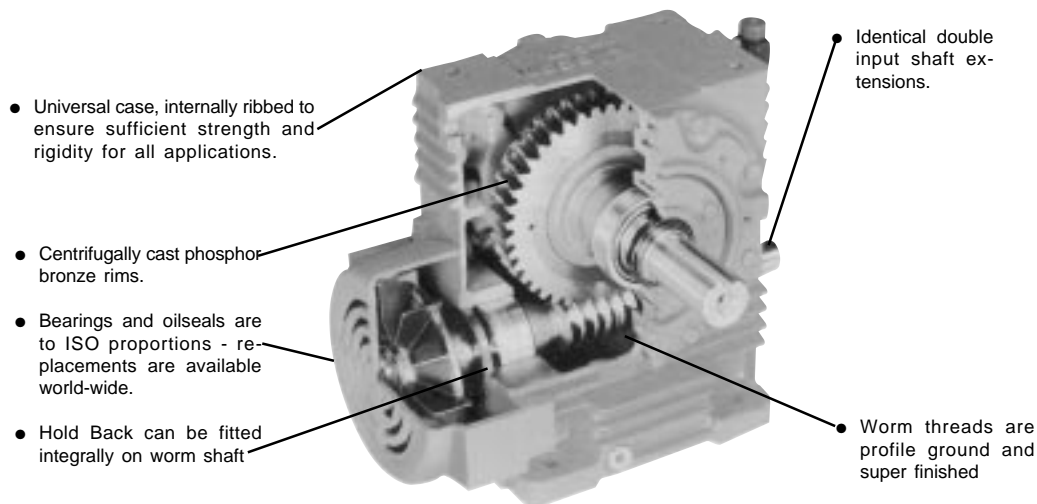

FILL AND FORGET Concept

The low and medium power gearunit sizes $1\frac{5}{8}$, $1\frac{3}{4}$, 2, $2\frac{1}{4}$ and 3 are supplied with factory filled SYNTHETIC LUBRICANT and require no lubricant maintenance. User has not to fill any grade of lubricant.

Change or shaft handling

This is achieved easily and quickly by just replacing the cap from one end of the worm shaft only in the case of $1\frac{5}{8}$, $1\frac{3}{4}$, 2, $2\frac{1}{4}$ and 3 SNU gear units. It is not necessary to dismantle the complete gear unit. While in 4 SNU onwards, just replace the fan and fancowl from one end to other end of the worm shaft.

TABLE NO. 1 LOAD CLASSIFICATION BY APPLICATIONS

Driven Machine	Type of Load	Driven Machine	Type of Load
Agitators & mixers		Reciprocating	H
Pure Liquids, semi-liquids	U	Screw	M
Liquids and solids variable density	M	Food Industry	
Liquids with variable density	M	Beef slicer	M
Blowers		Cereal cooker	U
Centrifugal, vane	U	Laundry machines	
Lobe	M	Washers, tumblers	M
Brewing & distilling		Line shaft	M
Bottle machinery	U	Mills	
Brew kettle continuous duty	U	Hammers	H
Cookers, scale hopper (frequent starts)	M	Ball kilns, pebbles	M
Cane filling Machinery	U	Rod tumbling barrels	H
Cane knives	M	Cement kilns	M
Clarifiers•	U	Dryers and coolers	M
Classifiers	U	Mixers	
Clay-working machinery		Concrete mixers	M
brick press, briquette machine	H	Sugar industry	
Pug mill, clay-working machinery	M	Cane knives	M *
Compressors		Crushers	M *
Centrifugal	U	Mills	H *
Lobe	M	Oil industry	
Reciprocating multi-cylinder	M	Chillers	M
Reciprocating single-cylinder	H	Rotary kilns	M
Conveyors - Uniformly loaded or fed		Paper mill	
Apron, Belt, Bucket, Screw	U	Bleacher conveyor press, winder	
Conveyors - Heavy Duty - Not Uniformly fed		Calendars, agitators, beater and pulper	M
Apron, Belt, Bucket, Screw	M	Pumps	
Reciprocating and shaker	M	Centrifugal	U
Cranes		Reciprocating (three or more cylinders)	M
Main Hoist	M	Gear, lobe type	U
Bridge Travel	*	Rubber & plastic industry	
Crushers		Crackers	H *
Ore, Stone	H	Fixing mills	H *
Sugar	M	Laboratory equipment	M
Elevators		Refiners	M *
Bucket-uniform load	U	Sheeters	M *
Bucket-heavy load	M	Tubers and strainers	M *
Bucket-continuous load	U	Warming mills	M *
Centrifugal discharge	U	Tyre and Tube press	M *
Gravity discharge	U	Sand Mullers	M
Passenger lifts	*	Screens	
Fans		Air washing	U
Centrifugal	U	Rotary-stone / gravel	M
Induced draft	M	Textile industry	
Large (mine, industrial, etc.)	M	Batches	M
Light (small diameter)	U	Calendars	M
Cooling Towers	H	Dyeing machinery	M
Induced draft	*	Spinners	M
forced draft	*	Washers	M
Feeders		Winders	M
Apron	M	Wire-drawing, Flattening machine	M
Belt	M	Wire Winding machine	M
Disc.	U		

* Should be selected on the basis of 24 hours / day service only & consult Elecon.

ENQUIRY

1. Type of prime mover, KW rating, speed R.P.M.
2. Required reduction ratio & Handing.
3. Type of driven machine, actual power required, designed speed R.P.M., peak and shock (give magnitude and duration where possible).
4. Type of drive employed between
 - (i) Prime mover and reducer.
 - (ii) Reducer and driven machine
5. No. of hours / day the gear unit will be in operation.
6. Ambient conditions, i.e., temperature, humidity.
7. Whether holdback required ? Specify direction of rotation, if holdback is to be fitted.
8. Details of any external loads imposed on gear unit.
9. Give sketch of available space.

Explanation and use of ratings and service factors.

Gear unit selection is made by comparing actual loads with catalogue ratings. Catalogue ratings are based on a standard set of loading conditions whereas actual load conditions vary according to type of application. Service factors are therefore used to calculate an equivalent load to compare with catalogue ratings.

*** Mechanical ratings and service factor (F_M)**

Mechanical ratings measure capacity in terms of life and/or strength assuming 12 hr/day continuous running under uniform load conditions.

Catalogue ratings allow 100% overload at starting, breaking or momentarily during operations up to 12 hours per day.

TABLE NO.2 Mechanical service factor (F_M)

Prime mover	Duration of service hrs per day	Load classification - driven machine		
		Uniform	Moderate Shock	Heavy Shock
Electric motor, steam turbine or hydraulic motor	Under : 3	0.80	1.00	1.50
	3 to 10	1.00	1.25	1.75
	Over 10 to 24	1.25	1.50	2.00
Multi-cylinder internal combustion engine	Under : 3	1.00	1.25	1.75
	3 to 10	1.25	1.50	2.00
	Over 10 to 24	1.50	1.75	2.25
Single cylinder internal combustion engine	Under : 3	1.25	1.50	2.00
	3 to 10	1.50	1.75	2.25
	Over 10 to 24	1.75	2.00	2.50

- For Units subject to frequent starts/stops and overloads, also applications where high inertia loads are involved e.g. crane travel drives, slewing motion etc. consult Elecon.

*** Thermal ratings and Thermal service factor (F_T)**

Thermal ratings measure a unit's ability to dissipate heat, if they are not exceeded, the lubricant may overheat and break down resulting in failure of gear unit.

Thermal ratings are affected by ambient temperature and not by mechanical considerations such as increased running time and shock loads.

Catalogue ratings are given on 20°C ambient temperature allowing for a lubricant temperature rise to 100°C during operation as the unit transmit power and generate heat.

Thermal ratings calculated with unit fan cooling.

Thermal service factor F_T (Table No. 3) is used to modify the actual load according to prevailing ambient temperature.

TABLE NO. 3 THERMAL SERVICE FACTOR (F_T)

Ambient Temp °C	10	20	30	40	50	60
Factor	0.87	1.00	1.16	1.35	1.62	1.97

If the ambient temperature is other than 20°C, divide the catalogue thermal rating by the factor from Table No. 3

EXAMPLE - 1

Worm reduction gear having input (worm) above the wheel required for belt conveyor where non-uniform material is fed on conveyor belt, operating for 8 hours per day. Speed required at conveyor shaft is 50 rpm. The gear unit is driven directly using coupling by 7.5 KW, 1500 rpm electric motor.

SOLUTION

STEP : 1 Ratio required = $\frac{\text{Input speed}}{\text{Output speed}} = \frac{1500}{50} = 30:1$

STEP : 2 From Table No.1
 Drive m/c - Belt conveyor
 Material - Non uniform fed
 Type of Load - Moderate shock (M)

∴ From Table No.2

Mechanical service factor (Fm) = 1.25 for 8 hr/day operation

STEP : 3 Input power = Motor Power x Fm
 = 7.5 x 1.25
 = 9.375 KW

∴ From catalogue - Rating at Input 1500 rpm, Ratio - 30:1

Gear unit size : 6 Ratio - 30:1

Input Power = 12.2 KW

∴ Gear unit type/size : 6 SNU-O, Ratio - 30:1

EXAMPLE - 2

Worm reduction gear unit underdriven type is required to drive a bucket elevator heavily loaded, operating 24 hours per day at 29 rpm, transmitting 30 KW. The gear unit is directly driven using coupling by 1500 rpm of an electric motor. The ambient temperature is around 30°C on plant.

SOLUTION :

STEP : 1 Ratio required = $\frac{\text{Input speed}}{\text{Output speed}} = \frac{1500}{29} = 51.7:1$

Nearest standard ratio available is 50:1

STEP : 2 From Table No. 1
 Driven m/c - Bucket Elevator (Heavily Loaded)
 Type of Load - Moderate shock (M),

From Table No. 2

Mechanical service factor (Fm) = 1.50 for 24 running hrs/day continuous

STEP : 3 Equivalent output power (Mechanical) = 30 x 1.5 = 45 KW

∴ Equivalent output torque (Mechanical) = $\frac{9550 \times 45}{29} = 14818.96 \text{ Nm}$

From catalogue.

Refer rating at input speed 1500 rpm, Ratio - 50:1

∴ Gear unit size 14, ratio 50:1 having output torque (Mechanical) = 16457.4 Nm
 Input power (Mechanical) = 62 KW

STEP : 4 From Table No. 3 Thermal service factor (Ft) = 1.16
 For an ambient temp. of 30°C

∴ Equivalent output power (Thermal) = 30 KW x 1.16
 = 34.8 KW

∴ Equivalent output torque (Thermal) = $\frac{9550 \times 34.8}{29} = 11460 \text{ Nm.}$

- STEP : 5** From catalogue, rating at input 1500 rpm Ratio - 50:1, for 14 size
 Output torque (Thermal) = 10486.9 Nm, which is less than calculated equivalent
 Output torque (Thermal) = 11460 Nm
- ∴ Higher gear unit size 17 SFU, Ratio - 50:1 is to be selected where at input 1500 rpm
 Where, Output torque (Mechanical) = 29064 Nm and
 Input power (Mechanical) = 110 KW
- ∴ Required Input power
- $$= \frac{\text{Calculated equivalent output torque (Mech.)} \times \text{Rated power (Mech.)}}{\text{Rated output torque (Mech.)} \times F_m}$$
- $$= \frac{14818.96 \times 110}{29064 \times 1.5} = 37.39 \text{ KW}$$
- ∴ Nearest standard motor having 37 KW at 1500 rpm can be selected for the application.

EXAMPLE - 3

Worm reduction gear (underdriven type) required to drive a clay-working machine for continuous 10 hours/day. The power required at clay-working machine is 5 KW at 50 rpm, ambient temperature is 40°C. Also suggest an electric motor power at 1500 rpm to drive the gear unit.

SOLUTION :

STEP : 1 Ratio required = $\frac{\text{Input speed}}{\text{Output speed}} = \frac{1500}{50} = 30:1$

- STEP : 2** From Table No.1
 Driven m/c - Clay-working machinery, Type of Load - Moderate shock (M),
- ∴ From Table No.2
 Mechanical service factor (Fm) = 1.25 for 10 running hrs/day continuous
- ∴ From Table No.3
 Thermal service factor (Ft) = 1.35 at 40°C ambient temp.
- ∴ The higher of the above two service factor i.e. 1.35 is to be considered as a service factor.

STEP : 3 Equivalent output power = 5 KW x 1.35 = 6.75 KW

∴ Equivalent output torque = $\frac{9550 \times 6.75}{50} = 1289.25 \text{ Nm}$

- STEP : 4** From catalogue, Refer rating at Input speed 1500 rpm, Ratio - 30:1
 Gear unfit size 6 SNU-U, Ratio 50:1 having
 Input power = 12.2 KW
 Output torque = 1980.7 Nm

STEP : 5 Required Input power

$$= \frac{\text{Calculated equivalent output torque} \times \text{Rated input power}}{\text{Rated output torque} \times \text{Service factor}}$$

$$= \frac{1289.25 \times 12.2}{1980.7 \times 1.35} = 5.88 \text{ KW}$$

∴ Suggest nearest standard A.C. electric motor having 7.5 KW at 1500 rpm to drive gear unit size 6 SNU-U, Ratio 30:1.



RATINGS AT INPUT SPEED 1500 R.P.M.

GEAR RATIO	OUTPUT SPEED R.P.M.	CAPACITY	SIZE OF UNIT				
			$1\frac{5}{8}$	$1\frac{3}{4}$	2	$2\frac{1}{4}$	3
5	300	INPUT POWER KW	1.46	2	2.9	3.8	8
		OUTPUT TORQUE Nm	44.2	56.6	83.1	112.5	231.8
7.5	200	INPUT POWER KW	1.3	1.45	2.2	3	6.86
		OUTPUT TORQUE Nm	54.6	61	92.4	127	294.8
10	150	INPUT POWER KW	1.2	1.3	1.75	2.8	5.75
		OUTPUT TORQUE Nm	69.5	74.5	97	146	325.8
15	100	INPUT POWER KW	1.14	1.2	1.6	1.9	4.13
		OUTPUT TORQUE Nm	90.36	96.3	122.2	154.2	347.1
20	75	INPUT POWER KW	0.8	0.83	1.5	1.62	3.78
		OUTPUT TORQUE Nm	86.6	88.8	149	161	404.3
25	60	INPUT POWER KW	0.7	0.72	1.3	1.44	3.15
		OUTPUT TORQUE Nm	79.1	90	155.1	176.5	411.1
30	50	INPUT POWER KW	0.6	0.63	1.15	1.3	2.75
		OUTPUT TORQUE Nm	85.6	91.5	160.3	186.2	430.7
40	37.5	INPUT POWER KW	0.45	0.5	0.8	0.97	2.27
		OUTPUT TORQUE Nm	88	94.3	146.7	177.9	439.4
50	30	INPUT POWER KW	0.34	0.36	0.65	0.72	1.82
		OUTPUT TORQUE Nm	70.4	78	145	160.4	423
60	25	INPUT POWER KW	0.3	0.31	0.45	0.55	1.6
		OUTPUT TORQUE Nm	58.5	75.8	110	140.7	434
70	21.4	INPUT POWER KW	0.26	0.27	0.4	0.43	1.3
		OUTPUT TORQUE Nm	58.1	74	107	124.7	406.1

GEAR RATIO	OUTPUT SPEED R.P.M.	CAPACITY	SIZE OF UNIT						
			$3\frac{1}{2}$	4	5	6	7	8	9
5	300	INPUT POWER KW	12.5	14.1	23.5	41	55	72	82.4
		OUTPUT TORQUE Nm	362.1	420.1	710.6	1253	1646.6	2177.4	2491.2
7.5	200	INPUT POWER KW	8	10	18.2	27	43.2	58	63.4
		OUTPUT TORQUE Nm	343.8	444.1	820	1211.9	1935	2603	2933.2
10	150	INPUT POWER KW	7	8.5	16.5	24	33.1	46	74.5
		OUTPUT TORQUE Nm	392.2	503.3	966.5	1444	1952.3	2753	4506
15	100	INPUT POWER KW	6	7	12	21.5	30	40	56
		OUTPUT TORQUE Nm	492.8	568.2	986	1827.4	2580	3514.4	5027
20	75	INPUT POWER KW	4.6	6.1	11.5	16.2	25.8	31.2	48
		OUTPUT TORQUE Nm	503.7	652.8	1205.2	1836.8	2814	3496.1	5447.3
25	60	INPUT POWER KW	4	5	9	13	20	28	42
		OUTPUT TORQUE Nm	547.5	684.4	1218.3	1810.5	2706	3788.2	6061.5
30	50	INPUT POWER KW	3.6	4.5	7.5	12.2	17	23	40
		OUTPUT TORQUE Nm	550	747.8	1217.6	1980.7	2760	3778	6876
40	37.5	INPUT POWER KW	2.8	3.8	5.8	10.4	15	20	32
		OUTPUT TORQUE Nm	549.1	754.8	1168	2118.8	3132.4	4278.4	7253
50	30	INPUT POWER KW	2.1	3	5	8.5	13	17	27
		OUTPUT TORQUE Nm	508	764	1257.4	2088.4	3228	4437.5	7220
60	25	INPUT POWER KW	1.8	2.6	4.2	7	11	14	22
		OUTPUT TORQUE Nm	515.7	739.9	1171.2	2032.2	3193.5	4011	6597
70	21.4	INPUT POWER KW	1.13	2.3	3.6	5.8	8.5	11.3	19
		OUTPUT TORQUE Nm	462.3	759.5	1124.6	1811.8	2769.1	3782	6868

- The Ratings are based on service factor of 1, continuously transmitted for 12 hours/day with normal overload of 100% momentarily for 15 seconds, 40% for 30 minutes, 25% for 2 hours.
- See Page No. 9 for actual service factor to nature of load and duration of operation.
- Ratios and output speeds are nominal. Exact ratios are listed on Page No. 30
- Higher rating can be obtained by using SYNTHETIC OIL, details on Page No. 32



RATINGS AT INPUT SPEED 1000 R.P.M.

GEAR RATIO	OUTPUT SPEED R.P.M.	CAPACITY	SIZE OF UNIT				
			$1\frac{5}{8}$	$1\frac{3}{4}$	2	$2\frac{1}{4}$	3
5	200	INPUT POWER KW	1.17	1.3	2.8	3	6.1
		OUTPUT TORQUE Nm	55.9	54.6	119	129.6	262.1
7.5	133	INPUT POWER KW	0.95	0.98	1.95	2.4	5.23
		OUTPUT TORQUE Nm	58	60.5	122.8	155	338
10	100	INPUT POWER KW	0.85	0.9	1.57	1.65	4.58
		OUTPUT TORQUE Nm	72.4	70.5	137.9	141.8	389.3
15	66.7	INPUT POWER KW	0.82	0.85	1.5	1.6	3.84
		OUTPUT TORQUE Nm	103.3	96.1	195.4	208.5	483.8
20	50	INPUT POWER KW	0.7	0.8	1.45	1.55	2.8
		OUTPUT TORQUE Nm	107	119.2	213.3	236.8	470.6
25	40	INPUT POWER KW	0.6	0.72	1.18	1.3	2.33
		OUTPUT TORQUE Nm	114.6	123.8	210.71	232.8	472.8
30	33.4	INPUT POWER KW	0.54	0.6	0.85	1.21	2
		OUTPUT TORQUE Nm	112.7	121.8	177.4	256	468.9
40	25	INPUT POWER KW	0.42	0.54	0.73	0.82	1.88
		OUTPUT TORQUE Nm	112.3	136.1	189.6	216.1	574.5
50	20	INPUT POWER KW	0.3	0.4	0.6	0.73	1.45
		OUTPUT TORQUE Nm	70.2	122.2	182.8	226.6	498.5
60	16.7	INPUT POWER KW	0.24	0.31	0.39	0.49	1.26
		OUTPUT TORQUE Nm	67.25	113.5	127.1	161.2	490
70	14.3	INPUT POWER KW	0.2	0.22	0.33	0.39	1.12
		OUTPUT TORQUE Nm	65.5	88.2	127.8	148.5	486.2

GEAR RATIO	OUTPUT SPEED R.P.M.	CAPACITY	SIZE OF UNIT						
			$3\frac{1}{2}$	4	5	6	7	8	9
5	200	INPUT POWER KW	10.56	12.2	22.2	32.23	46.5	59.1	64.4
		OUTPUT TORQUE Nm	451.8	553.4	1022.9	1462	2087.2	2717.6	2912
7.5	133	INPUT POWER KW	6.86	9.04	17	25	37	47.46	54.1
		OUTPUT TORQUE Nm	438.4	610.2	1147.4	1687.4	2497.4	3254.5	3682.1
10	100	INPUT POWER KW	6.6	7.8	14.59	22.4	28.24	38.5	48.5
		OUTPUT TORQUE Nm	554.7	692.8	1295.8	2010.8	2481.2	3492.9	4400
15	66.7	INPUT POWER KW	5	6.5	9.3	16.5	24.2	29.5	37.3
		OUTPUT TORQUE Nm	615.7	856.2	1225	2197.1	3187.7	3928.1	4966
20	50	INPUT POWER KW	4.3	6.2	8.8	13	17.5	24.2	30.8
		OUTPUT TORQUE Nm	698.1	1065.8	1462.3	2185	2874.6	3882.6	5471
25	40	INPUT POWER KW	3.15	5	7.1	10.2	15.6	21	27
		OUTPUT TORQUE Nm	601.7	1026.6	1440.9	2094.3	3203.1	4412.1	5673
30	33.4	INPUT POWER KW	2.9	4.2	6.2	9	14.23	18.8	23.2
		OUTPUT TORQUE Nm	646.8	1008.8	1524.6	2187.4	3417.8	4569.1	5722
40	25	INPUT POWER KW	2.5	3.72	4.9	7.8	11	14.5	20
		OUTPUT TORQUE Nm	716.3	1122.6	1516.2	2383.7	3445.6	4542	6417
50	20	INPUT POWER KW	1.8	2.6	4.2	6.6	9.6	13	15.4
		OUTPUT TORQUE Nm	601.6	918.7	1544.2	2426.7	3529.7	4966	5956.3
60	16.7	INPUT POWER KW	1.43	2.22	3.6	5.4	8.2	11	13.1
		OUTPUT TORQUE Nm	547.9	939.4	1482.3	2254.3	3423.1	4717.8	5993
70	14.3	INPUT POWER KW	1.21	2.16	3.13	4.6	6.9	8.88	10.1
		OUTPUT TORQUE Nm	484.8	980.9	1463.2	2089	3317.8	4210.5	5961.2

- The Ratings are based on service factor of 1, continuously transmitted for 12 hours/day with normal overload of 100% momentarily for 15 seconds, 40% for 30 minutes, 25% for 2 hours.
- See Page No. 9 for actual service factor to nature of load and duration of operation.
- Ratios and output speeds are nominal. Exact ratios are listed on Page No. 30
- Higher rating can be obtained by using SYNTHETIC OIL, details on Page No. 32



RATINGS AT INPUT SPEED 750 R.P.M.

GEAR RATIO	OUTPUT SPEED R.P.M.	CAPACITY	SIZE OF UNIT				
			$1\frac{5}{8}$	$1\frac{3}{4}$	2	$2\frac{1}{4}$	3
5	150	INPUT POWER KW	0.98	1.14	1.8	2.1	4.04
		OUTPUT TORQUE Nm	54.7	63.5	110.6	117.3	234.1
7.5	100	INPUT POWER KW	0.77	0.8	1.34	1.45	3.5
		OUTPUT TORQUE Nm	60.5	63.4	110.1	123.9	310.9
10	75	INPUT POWER KW	0.58	0.65	1.12	1.24	3.21
		OUTPUT TORQUE Nm	60.6	67.9	119.8	137.4	372
15	50	INPUT POWER KW	0.52	0.53	0.85	0.93	2.16
		OUTPUT TORQUE Nm	72.5	81	128.3	151	350.7
20	37.5	INPUT POWER KW	0.45	0.48	0.76	0.86	1.85
		OUTPUT TORQUE Nm	78.6	95.4	151	170.8	391
25	30	INPUT POWER KW	0.38	0.42	0.56	0.75	1.7
		OUTPUT TORQUE Nm	78.6	97.6	139.1	181.5	432.9
30	25	INPUT POWER KW	0.36	0.38	0.48	0.6	1.5
		OUTPUT TORQUE Nm	82.5	101.6	135.7	176.5	435.5
40	18.8	INPUT POWER KW	0.32	0.36	0.4	0.45	1.4
		OUTPUT TORQUE Nm	89.4	124.4	138.2	160	526.3
50	15	INPUT POWER KW	0.24	0.28	0.32	0.39	1.28
		OUTPUT TORQUE Nm	79.5	94.5	138.5	168.8	570.5
60	12.5	INPUT POWER KW	0.2	0.23	0.28	0.31	1.12
		OUTPUT TORQUE Nm	79.5	87.9	139.1	154	564.8
70	10.7	INPUT POWER KW	0.16	0.18	0.2	0.26	0.87
		OUTPUT TORQUE Nm	75.7	88.4	108.9	150.8	520.3

GEAR RATIO	OUTPUT SPEED R.P.M.	CAPACITY	SIZE OF UNIT						
			$3\frac{1}{2}$	4	5	6	7	8	9
5	150	INPUT POWER KW	7.15	10.47	17	24.03	32.61	42.91	45.48
		OUTPUT TORQUE Nm	409.7	619.9	1014.2	1442.7	1964.1	2592.6	2753.7
7.5	100	INPUT POWER KW	5.83	8.1	15.1	21.45	29.18	39.48	42.91
		OUTPUT TORQUE Nm	478.8	707.1	1333.9	1911.2	2600	3544.1	3864.3
10	75	INPUT POWER KW	5.52	6.3	11.59	16.91	23.17	30.04	36.04
		OUTPUT TORQUE Nm	611.5	722	1338.5	1916.4	2723.14	3538.2	4295.4
15	50	INPUT POWER KW	4.1	5.2	8	13.13	18.02	24.15	28.3
		OUTPUT TORQUE Nm	673.5	795	1333.7	2221.9	3118.3	4202.1	4884.4
20	37.5	INPUT POWER KW	3.5	3.7	6.44	10	13.5	18	23.2
		OUTPUT TORQUE Nm	737.1	782.8	1387.5	2181	2993.5	4001.7	5180.8
25	30	INPUT POWER KW	2.8	3.11	5.5	7.82	12.1	16.31	19.74
		OUTPUT TORQUE Nm	739.8	760.3	1267.6	2078.6	3270.2	4449.6	5423
30	25	INPUT POWER KW	2.3	2.75	4.8	7.4	11.33	14.08	17
		OUTPUT TORQUE Nm	682.3	772.1	1420.3	2252.5	3492.7	4335.1	5374.4
40	18.8	INPUT POWER KW	1.77	2.14	3.7	5.75	8.33	10.6	13.3
		OUTPUT TORQUE Nm	660.9	751.2	1336.5	2234.5	3228.6	4122.2	5371.1
50	15	INPUT POWER KW	1.47	1.81	3.17	5.15	8	9.44	11
		OUTPUT TORQUE Nm	627.1	790.5	1374.4	2347.6	3739.3	4501.6	5253.3
60	12.5	INPUT POWER KW	1.27	1.73	2.92	4.21	7	8.66	10
		OUTPUT TORQUE Nm	628.2	867.1	1470.2	2196.8	3632.1	4518.9	5737.5
70	10.7	INPUT POWER KW	1.12	1.46	2.58	3.61	5.5	7	8.4
		OUTPUT TORQUE Nm	599.8	831.4	1538.2	2255.4	3475.5	4572	5585.4

- The Ratings are based on service factor of 1, continuously transmitted for 12 hours/day with normal overload of 100% momentarily for 15 seconds, 40% for 30 minutes, 25% for 2 hours.
- See Page No. 9 for actual service factor to nature of load and duration of operation.
- Ratios and output speeds are nominal. Exact ratios are listed on Page No. 30
- Higher rating can be obtained by using SYNTHETIC OIL, details on Page No. 32



RATINGS AT INPUT SPEED 500 R.P.M.

GEAR RATIO	OUTPUT SPEED R.P.M.	CAPACITY	SIZE OF UNIT				
			1 $\frac{5}{8}$	1 $\frac{3}{4}$	2	2 $\frac{1}{4}$	3
5	100	INPUT POWER KW	0.72	0.86	1.4	1.52	3.46
		OUTPUT TORQUE Nm	61.9	74.3	120.3	132.1	300.7
7.5	66.7	INPUT POWER KW	0.61	0.88	0.95	1.16	3.65
		OUTPUT TORQUE Nm	81.2	85.1	114.3	144.5	388.7
10	50	INPUT POWER KW	0.47	0.5	0.85	0.98	2.6
		OUTPUT TORQUE Nm	73.3	80.2	133.1	161.6	442
15	33.3	INPUT POWER KW	0.41	0.44	0.68	0.74	1.9
		OUTPUT TORQUE Nm	85.8	102.2	156	179.2	468.6
20	25	INPUT POWER KW	0.32	0.35	0.51	0.62	1.36
		OUTPUT TORQUE Nm	89.2	107.3	156	189.5	431.2
25	20	INPUT POWER KW	0.3	0.33	0.43	0.49	1.23
		OUTPUT TORQUE Nm	100.3	113.5	173	175.5	469.9
30	16.6	INPUT POWER KW	0.27	0.3	0.36	0.42	1.15
		OUTPUT TORQUE Nm	101	117.4	175	176.4	502.8
40	12.5	INPUT POWER KW	0.23	0.27	0.33	0.37	0.93
		OUTPUT TORQUE Nm	98.4	115.5	164	192.2	525.8
50	10	INPUT POWER KW	0.19	0.21	0.25	0.3	0.85
		OUTPUT TORQUE Nm	96.8	108.3	153	180	592.6
60	8.33	INPUT POWER KW	0.17	0.19	0.21	0.25	0.7
		OUTPUT TORQUE Nm	98.8	111.1	149.2	172	561.8
70	7.14	INPUT POWER KW	0.13	0.16	0.16	0.2	0.65
		OUTPUT TORQUE Nm	88.7	106.4	124.1	155.2	599.9

GEAR RATIO	OUTPUT SPEED R.P.M.	CAPACITY	SIZE OF UNIT						
			3 $\frac{1}{2}$	4	5	6	7	8	9
5	100	INPUT POWER KW	6.1	7.65	12.36	16.8	24.2	31.34	40
		OUTPUT TORQUE Nm	524.3	674	1086	1476.1	2103.1	2723.6	3476.2
7.5	66.7	INPUT POWER KW	4.2	5.5	10	14.4	21.5	28.65	33
		OUTPUT TORQUE Nm	511.2	722.4	1315.8	1882.4	2792.1	3765.7	4309.1
10	50	INPUT POWER KW	3.52	4.6	8.67	12.6	6.7	23.3	28
		OUTPUT TORQUE Nm	567.4	790	1488.7	2158.7	2806	4125.4	4813.2
15	33.3	INPUT POWER KW	2.8	3.72	6	9.7	13.4	18.12	24
		OUTPUT TORQUE Nm	669.7	925.8	1507.4	2439.7	3381.8	4413.3	6125.8
20	25	INPUT POWER KW	2.2	3.1	5.2	7.55	10.5	13.3	17.5
		OUTPUT TORQUE Nm	687	1005.4	1696.4	2468.8	3425.4	4476	6009.8
25	20	INPUT POWER KW	1.75	2.5	4.6	6.6	9.4	12.1	14.5
		OUTPUT TORQUE Nm	651.8	981.3	1838.5	2644.1	3779.3	5032.4	6120.6
30	16.6	INPUT POWER KW	1.66	2	3.8	5.8	8	10.65	13
		OUTPUT TORQUE Nm	802.2	935.4	1748.9	2652.7	3649.7	5158.9	6491.7
40	12.5	INPUT POWER KW	1.35	1.6	3.1	4.8	6.8	8.67	9.78
		OUTPUT TORQUE Nm	835.4	951	1807.1	2801.7	3979.5	5067.3	6194.2
50	10	INPUT POWER KW	1.1	1.43	2.58	4	6.6	7.5	8.7
		OUTPUT TORQUE Nm	787.8	1002.4	1747	2765.7	4027.6	5386.2	6480.6
60	8.33	INPUT POWER KW	0.93	1.27	2.12	3.2	5.15	6.25	7.5
		OUTPUT TORQUE Nm	778.3	975.5	1487.5	2557.1	4097.6	5015.8	6577.8
70	7.14	INPUT POWER KW	0.8	1.1	1.8	2.85	4.14	5.55	6.6
		OUTPUT TORQUE Nm	792	978.4	1555.3	2470.2	3593.8	4973.6	6444.2

- The Ratings are based on service factor of 1, continuously transmitted for 12 hours/day with normal overload of 100% momentarily for 15 seconds, 40% for 30 minutes, 25% for 2 hours.
- See Page No. 9 for actual service factor to nature of load and duration of operation.
- Ratios and output speeds are nominal. Exact ratios are listed on Page No. 30
- Higher rating can be obtained by using SYNTHETIC OIL, details on Page No. 32

WORM GEAR MOTOR-SWM



These models are easily adaptable for various types of mountings such as underdriven, overdriven or vertical where avoids the mounting requirement of prime mover.

The flange mounting type motors of various rpm are adaptable to the worm reducer with adaptor housing. The solid motor shaft is coupled with hollow worm shaft by means of key, (1 3/4 and 2 1/4 size) and incase 3 and 4 size coupling is provided where it allows easier removal of the motor for maintenance, if any. Which leads to advantages (a) Comprehensive maintenance of inhouse stock and in turn faster delivery (b). Quick interchangeability of handing as well from underdriven to overdriven.

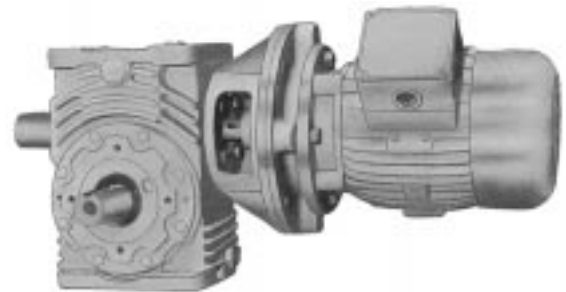

1 3/4 SWM-U-71

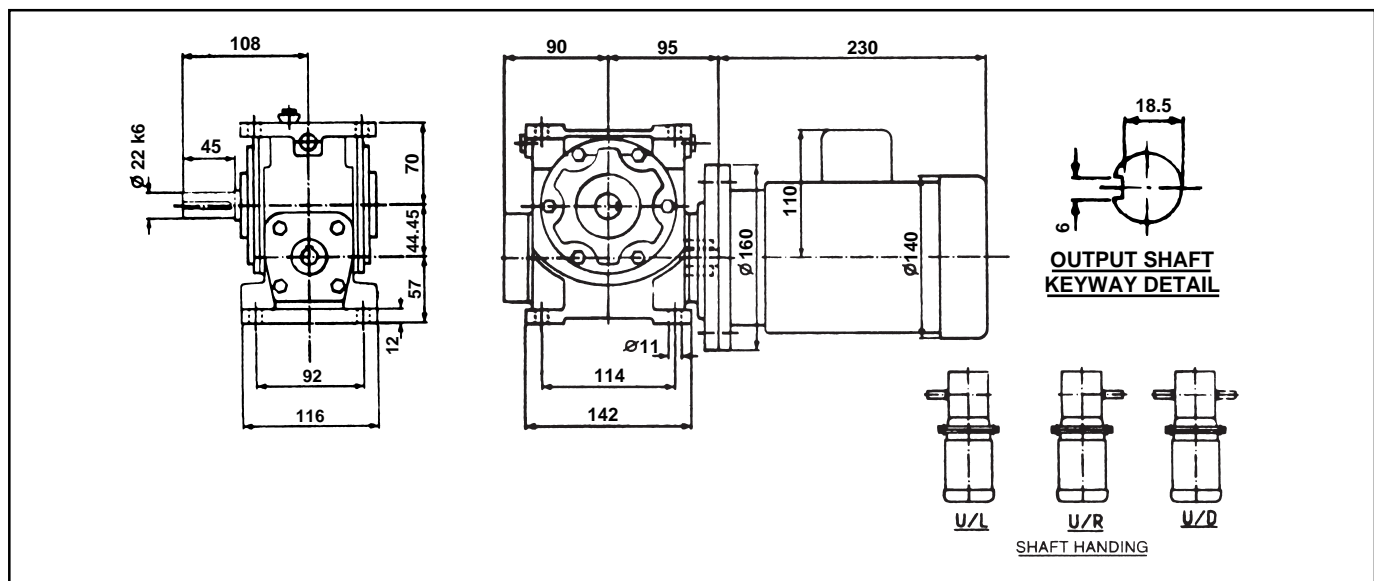

1 3/4 SWM-O-71

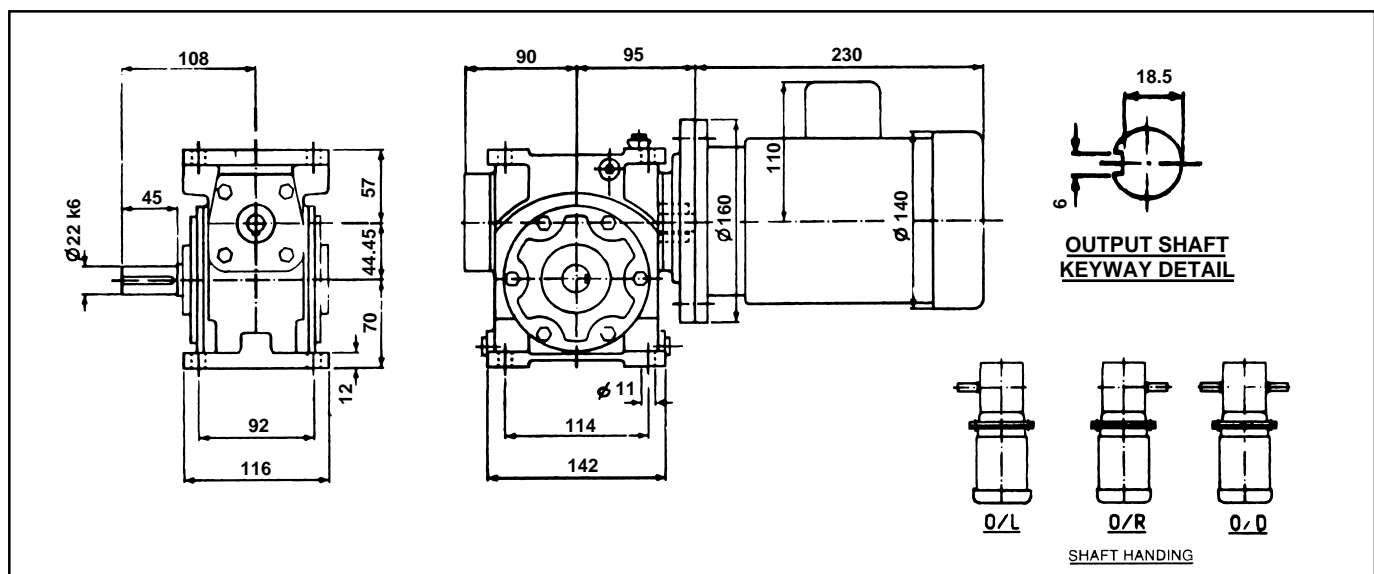

Key & Keyways as per IS 2048. Shaft limits up to 58dia.-k6 and above 58 dia.-m6

2 1/4 SWM-U-80

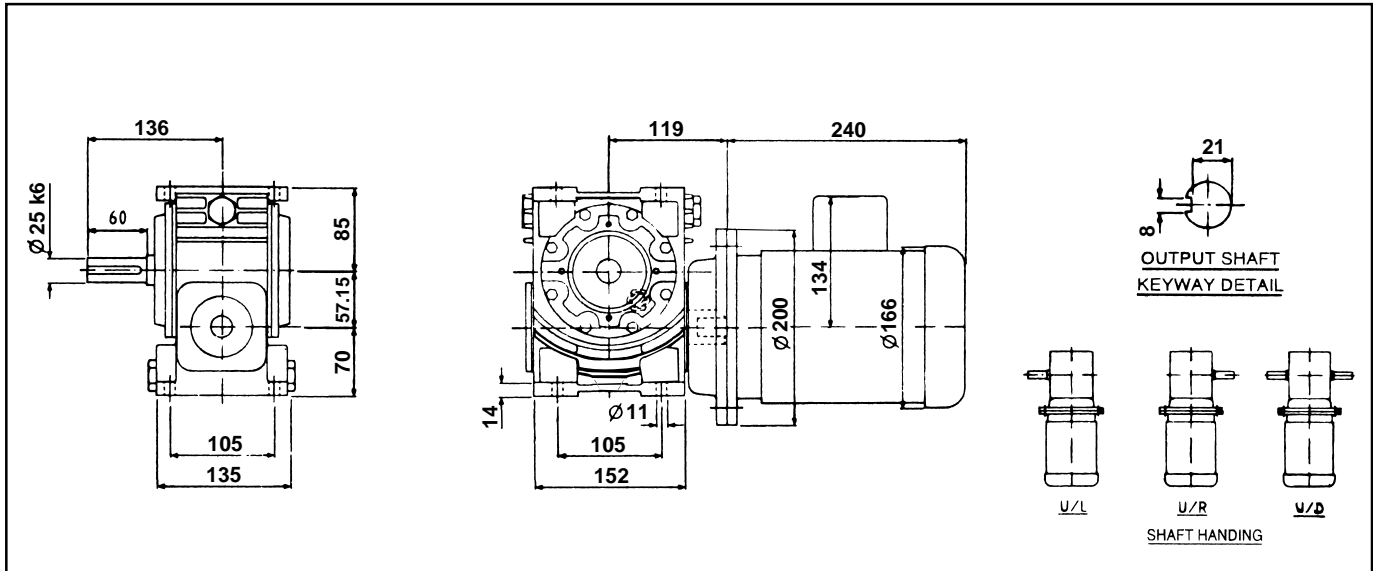

2 1/4 SWM-O-80

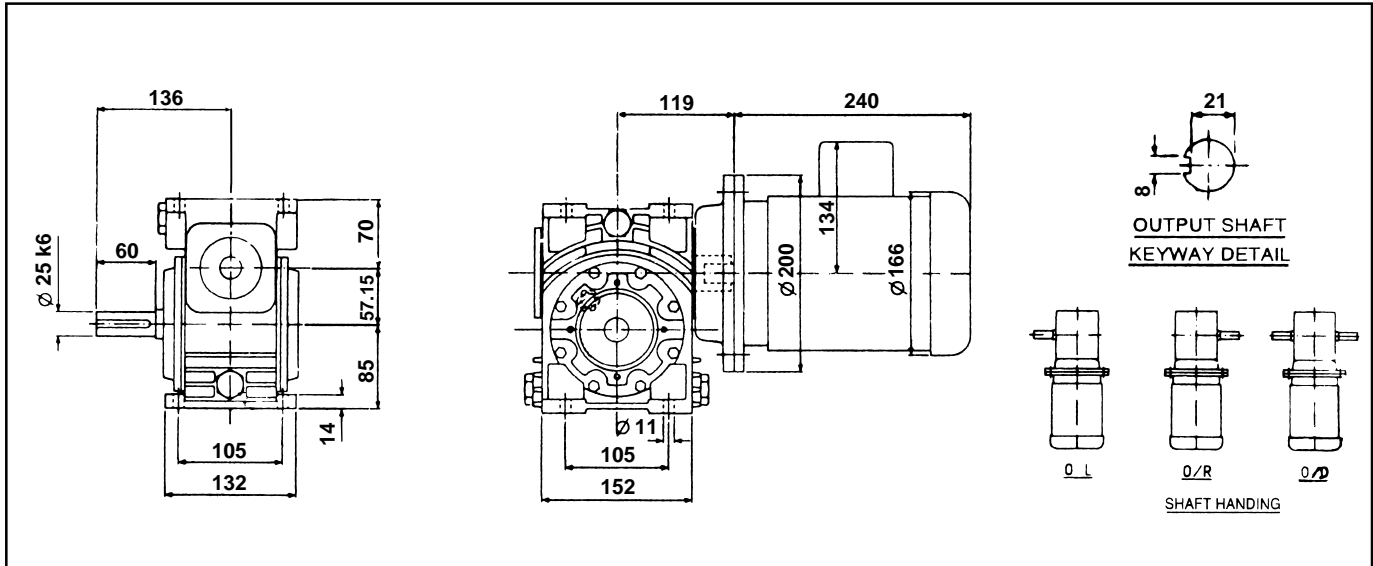

3 SWM-U

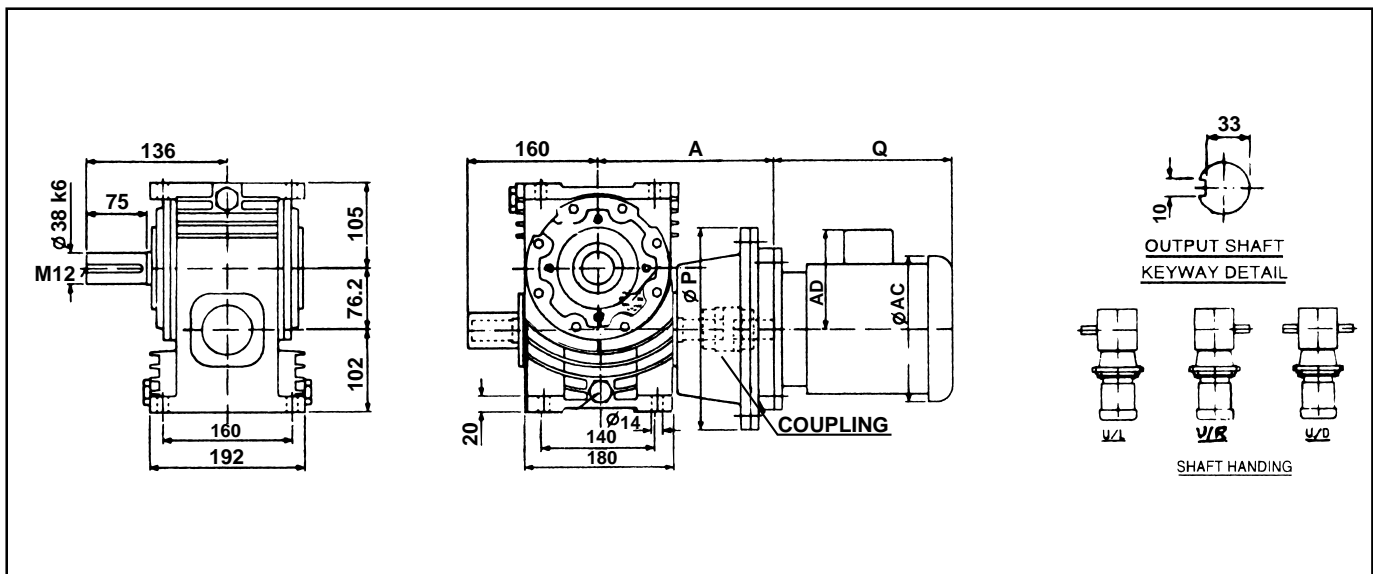

Key & Keyways as per IS 2048. Shaft limits upto 58dia.-k6 and above 58 dia.-m6

3 SWM-O

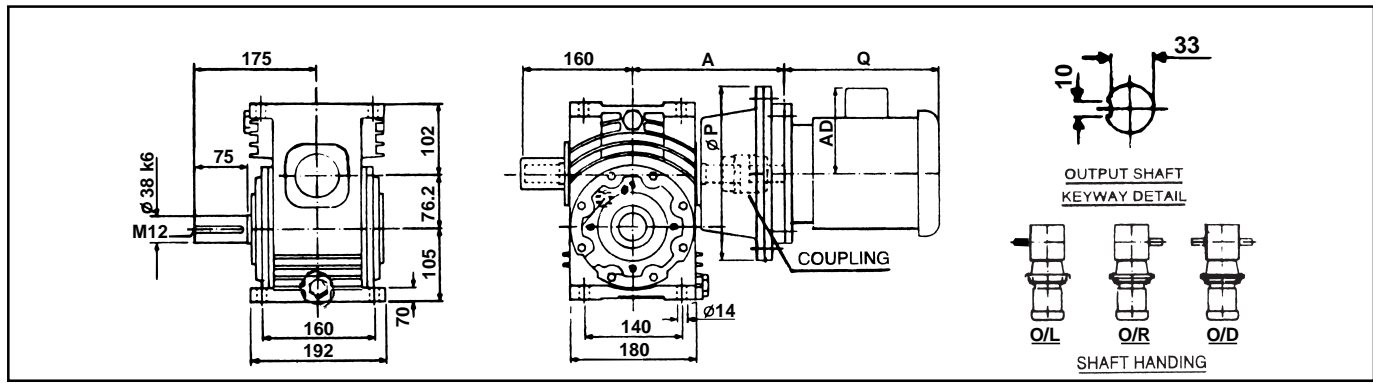

GEAR SIZE	MOTOR FRAME SIZE	MOTOR KW @			DIMENSIONS					GEAR SIZE
		1500	1000	750	A	P	Q	AC	AD	
3 SWM-U-80K	80-K	0.55	0.37	0.20	208	250	230	156	122	3 SWM-O-80K
3 SWM-U-80N	80-N	0.75	0.55	0.25	280	250	230	156	122	3 SWM-O-80N
3 SWM-U-90S	90-S	1.10	0.75	0.37	218	250	240	476	133	3 SWM-O-90S
3 SWM-U-90L	90-L	1.50	1.10	0.55	218	250	265	176	133	3 SWM-O-90L
3 SWM-U-100L	100-L	2.20	1.50	1.10	228	250	298	212	146	3 SWM-O-100L
3 SWM-U-112S	112-S	3.70	2.20	1.50	228	250	318	234	170	3 SWM-O-112S

4 SWM-U

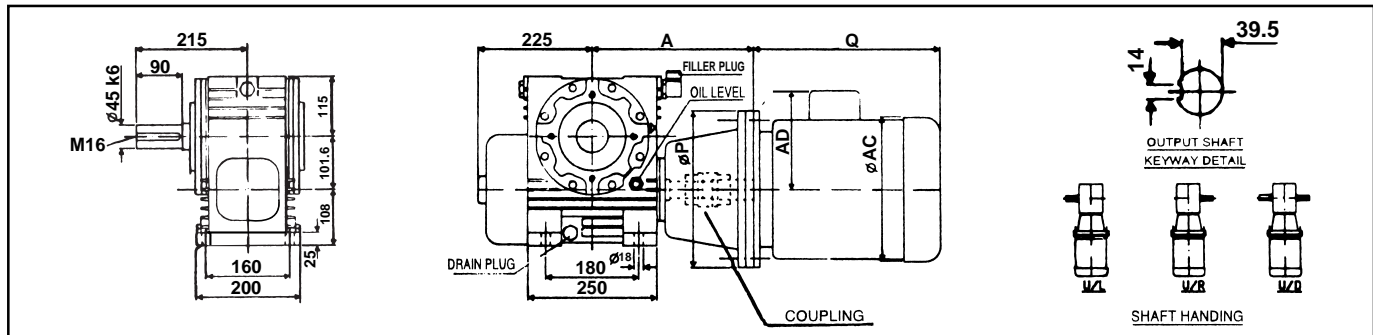

4 SWM-O

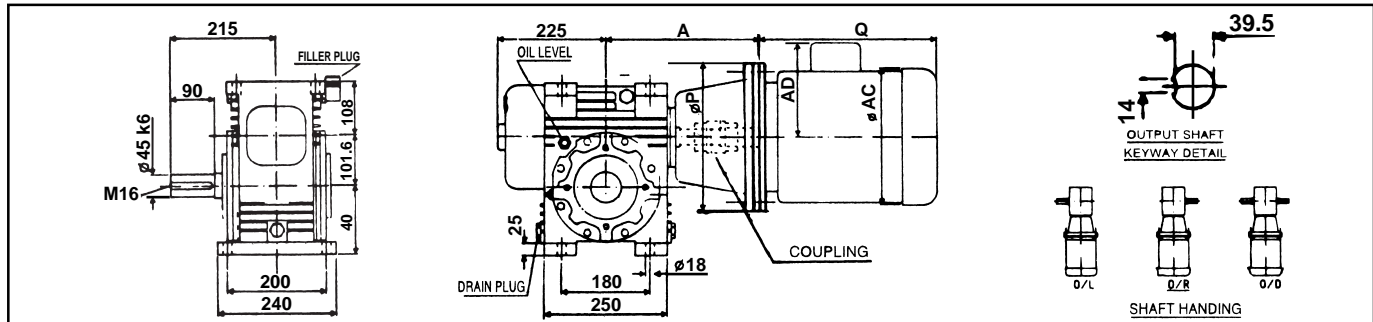

GEAR SIZE	MOTOR FRAME SIZE	MOTOR KW @			DIMENSIONS					GEAR SIZE
		1500	1000	750	A	P	Q	AC	AD	
4 SWM-U-80K	80-K	0.55	0.37	0.20	273	250	230	156	122	4 SWM-O-80K
4 SWM-U-80N	80-N	0.75	0.55	0.25	273	250	230	156	122	4 SWM-O-80N
4 SWM-U-90S	90-S	1.10	0.75	0.37	283	250	240	176	133	4 SWM-O-90S
4 SWM-U-90L	90-L	1.50	1.10	0.55	283	250	265	176	133	4 SWM-O-90L
4 SWM-U-100L	100-L	2.20	1.50	1.10	293	250	298	212	146	4 SWM-O-100L
4 SWM-U-112M	112-M	3.70	2.20	1.50	293	250	318	234	170	4 SWM-O-112M
4 SWM-U-132S	132-S	5.50	3.70	2.20	313	300	360	274	189	4 SWM-O-132S
4 SWM-U-132M	132-M	7.50	5.50	3.00	313	300	398	274	189	4 SWM-O-132M
4 SWM-U-160M	160-M	11.00	7.50	5.50	347	350	472	335	233	4 SWM-O-160M

Dimensions 'AC' and 'Q' are Subject to change as per motor make. Key & Keyways as per IS 2048. Shaft limits up to 58dia.-k6 and above 58 dia.-m6



ACTUAL GEAR RATIO

SIZE OF UNIT	NOMINAL RATIO										
	5	7.5	10	15	20	25	30	40	50	60	70
1 5/8	5.25	7.33	10.5	14.5	20	25	30	40	50	60	70
1 3/4	5.20	7.33	9.66	14.5	21	26	29	40	50	60	70
2	5	7.5	9.5	15	19	25	30	40	50	61	70
2 1/4	4.8	7	10.5	14.5	21	24	29	39	50	60	70
3	4.83	7.25	9.67	14.5	20	25	30	40	50	60	70
3.54	4.83	7.25	9.66	14.5	20	25	30	40	50	59	70
4	4.83	7.24	9.67	14.5	19.5	25	30	40	50	60	71
5	4.83	7.25	9.67	14.5	19.5	25	30	40	50	60	71
6	4.86	7.25	9.67	14.5	19.5	25	30	40	50	60	70
7	5.14	7.25	9.67	14.67	19.5	24.5	30	40	50	60	71
8	5.14	7.20	9.75	14.67	19.5	24.5	30	40	50	60	71
9	5.14	7.20	9.75	14.67	19.5	24.5	30	40	50	60	71
10.5	5.14	7.33	9.75	14.67	19.5	24.5	29.5	40	50	60	70
12	4.9	7.43	9.8	14.67	20.5	24.5	29.5	40	50	60	70
14	5.1	7.57	9.8	14.67	20.33	24.5	30.5	39	49	61	69
17	5.1	7.37	9.83	14.75	19.66	25.5	29.5	40	49	60	71

OVERHUNG LOADS :

Whenever a sprocket, gear, sheave or pulley is mounted on the output shaft, a calculation should be made to determine the overhung load in Newtons on the shaft, using the formula :

$$P = \frac{KW \times 9550 \times K}{N \times R}$$

Where, P = equivalent overhung load in Newtons
 KW = power carried by shaft in Kilo Watts
 N = r.p.m. of the shaft
 R = pitch radius of sprocket, pinion, sheave or pulley in meter
 K = factor

Overhung Member	K Factor
Sprocket	1.00
Spur Pinion	1.25
V-belt Sheave	1.50
Flat Belt Pulley	2.00

The calculated equivalent overhung load should be compared with the permissible values given in the table.

Maximum permissible overhung loads (Newtons) at centre of wheel shaft extension at 1500 r.p.m. Input Speed.

RATIO	BEARING NEAR SHAFT EXTENTION	SIZE OF UNIT															
		1 5/8	1 3/4	2	2 1/4	3	3.54	4	5	6	7	8	9	10.5	12	14	17
5	STD TRB	3080	3108	4840	4851	4857	4950	10454	12180	13636	15818	15900	16800	19800	22310	34654	
	STD TRB+CRB					9216	10351	11720	15800	20963	22230	24225	24335	29865	34650	50000	
7.5	STD TRB	3102	3080	4785	4796	5449	6600	11400	15090	16910	18900	19363	20010	22820	27000	40500	
	STD TRB+CRB					9981	10351	13300	17600	24280	23450	26035	27110	33340	36650	54975	
10	STD TRB	3102	3058	4708	4829	6151	7150	11120	16000	17636	19350	22335	22860	26325	32909	49363	55000
	STD TRB+CRB					10769	11088	15593	19500	25450	25630	31400	32000	33495	46636	69954	99000
15	STD TRB	2970	3047	4565	4400	7176	8272	10100	16620	17834	22300	24090	24000	28300	33050	50875	63594
	STD TRB+CRB					11924*	13750*	16600*	20110*	26575*	27780*	32800	33000	41000	55120	87089	130633
20	STD TRB	2893	2915	4400	4422	7877	9680	10252	15300	18014	23000	23800	26840	27715	33000	52080	65100
	STD TRB+CRB					12841*	15400*	17481*	22800*	27220*	27980*	34600*	44825*	44815*	57674*	92000*	138000*
25	STD TRB	2860	3135	4235	4345	8367	9295	10468	15545	18443	22250	24604	28600	28900	32636	65270	78824
	STD TRB+CRB					12734*	16375*	17481*	24700*	27280*	29423*	35988*	47300*	48800*	57004*	117068*	151025*
30	STD TRB	2723	2750	4043	4378	8848	9130	11061	15000	19816	21386	25520	30800	29120	32800	67980	81576
	STD TRB+CRB					13165*	16500*	17914*	24400*	27468*	32373*	37769*	51150*	51200*	57800*	127545*	172185*
40	STD TRB	2695	2723	4059	4428	9874	10450	12194	16618	22170	24035	29675	34650	35325	31325	76726	88071
	STD TRB+CRB					14244*	17688*	18990*	25575*	30411*	37769*	41760*	52495*	52015*	63272*	140745*	182968*
50	STD TRB	2778	2640	4180	4565	10468	10780	13165	17805	24133	25506	31078	36740	33325	32080	83450	100148
	STD TRB+CRB					14838*	18832*	20126*	27366*	34335*	39710*	43812*	53000*	53800*	63305*	154935*	185922*
60	STD TRB	2893	2873	4312	4758	11762	11110	13813	18830	25133	26880	32481	31195	31800	34650	85535	102642
	STD TRB+CRB					16133*	20075*	20880*	29136*	37572*	42516*	45646*	53120*	54000*	67630*	138050*	179465*
70	STD TRB	3025	3060	4928	5148	14028	13695	14513	19747	26389	29234	34100	35320	30300	41580	86310	103572
	STD TRB+CRB					18345*	20350*	21474*	30269*	38357*	43066*	47696*	54000*	57475*	70950*	143484*	186530*

* SPECIAL HEAT - TREATED SHAFT IS SUPPLIED

TRB = TAPER ROLLER BEARING
 CRB = CYLINDRICAL ROLLER BEARING



AVERAGE WEIGHT IN KILOGRAMS

Gear Size	1 5/8		1 1/4		2		2 1/4		3		3.54		4		5		6		7		8		9		10.5	
	NET	GR.	NET	GR.	NET	GR.	NET	GR.	NET	GR.	NET	GR.	NET	GR.	NET	GR.	NET	GR.	NET	GR.	NET	GR.	NET	GR.	NET	GR.
SNU-U	7	8.5	8	10.5	12	23	14	25	32	60	40	65	65	95	95	125	152	190	180	230	220	270	319	385	460	585
SNU-O	7	8.5	8	10.5	12	23	14	25	32	60	40	65	72	102	105	135	165	204	195	265	237	305	336	400	480	600
SNU-V	7.3	9	8.5	11.5	14	24	15	25	37	67	43	68	73	103	105	135	166	205	200	270	250	315	348	430	481	610
SNU-SM	-	-	-	-	15	28	16	28	35	65	41	66	64	80	110	140	157	170	200	270	252	316	330	415	465	590

APPROXIMATE OIL CAPACITY FOR SNU GEAR UNIT IN LITRES

Gear Type	FILL AND FORGET									
SNU-U	2.5	2.5	4	5	9.5	11	16	21		
SNU-O	3.8	5.1	8	13.5	18	19	41	45		
SNU-V	3.5	4.0	5.7	8.5	18	20	25	26		

APPROXIMATE OIL CAPACITY FOR SNU-SM GEAR UNIT FOR DIFFERENT MOUNTING POSITIONS IN LITRES

Mounting Position	FILL AND FORGET									
A	4	5	7	10	18	19	41	45		
B	2.5	2.5	4	6	9.5	11	16	21		
C	2.5	2.5	4.7	8.8	18	20	25	26		
D/E	3	3.5	8	11.6	19	20	25	26		

		12	14	17	
SFU	Net Weight (kgs.)	580	885	1260	
	Gross Weight (kgs.)	900	1140	1700	
	Oil Capacity (ltrs.)	25	36	60	
SFO	Net Weight (kgs.)	660	940	1380	
	Gross Weight (kgs.)	920	1180	1800	
	Oil Capacity (ltrs.)	27	38	95	
SFV	Net Weight (kgs.)	660	870	1575	
	Gross Weight (kgs.)	845	1120	2000	
	Oil Capacity (ltrs.)	29	43	106	
SSM	Net Weight (kgs.)	780	1280	-	
	Gross Weight (kgs.)	940	1540	-	
	Approx. Oil Capacity in ltrs. For Diff. Mounting Positions	A	24	28	-
		B	22	25	-
		C	26	28	-
D/E		23	30	-	

- * Size 1 5/8 to 3 under 'FILL and FORGET' concept. i.e., Factory filled synthetic lubricant for lifetime lubrication
- * For higher sizes 3.54 to 17 first filling of oil is not supplied with the gear unit.
- * First change of oil should be made after 500 hrs. of operation.
- * Subsequent oil change must be made after every 3000 hours of operation. The interval should not exceed 12 months.

RECOMMENDED LUBRICANTS

I MINERAL OIL :

Brand	Grade
International Brands	
British Petroleum	CS 320 or GR-XP320
Castrol	Alpha Zn 320 or Alpha Sp-320 or Tribol 1100/320 TGQA
Caltex	Meropa 320
Esso Petroleum	Teresso 320 or Spartan 320
Fuchs	Renolin CKC 320
Mobil Oil Co.	Mobil DTE Oil AA or Mobilgear 632
Shell Co.	Vitera Oil 320 or Omela 320
Indian Brands	
Bharat Petroleum	Cabol 320
Balmer Lawrie Fuchs	Renolin CKC 320
Castrol	Alpha Zn 320 or Alpha Sp-320 or Tribol 1100/320 TGQA
Gulf	Gulf harmony 320 or Gulf EP 320
Hindustan Petroleum	Enklo 320 or Parthan EP 320
Indian Oil	Servomesh SP 320 or Servosystem 320
Veedol	Avalon 320

Recommended Grease : For low speed of operations.

Brand	Grade
Castrol	EPL 2
Indian Oil	SERVOGEM EP 2

II POLYGLYCOL BASED SYNTHETIC LUBRICANT

* USE OF POLYGLYCOL BASED SYNTHETIC LUBRICANT IS ALSO ADVISABLE TO IMPROVE THE TRANSMITTING CAPACITY (RATING) OF GEAR UNITS MIN. 20% AS COMPARED WITH USE OF MINERAL OIL AT SAME WORKING TEMPERATURE. THIS GEAR OIL SHOWS EXCELLENT NON-AGEING STABILITY WITH FAVOURABLE INFLUENCE ON EFFICIENCY.

Approved Synthetic Lubricants

Brand	Grade
Castrol	Tribol 800-220
Fuchs	Renolin PG 220

Special Note : Synthetic Lubricants must not be mixed with any other type of oil. The gear unit must be flushed while changing to or from this lubricant.

MOUNTING POSITIONS AND SHAFT HANDING :

B – Breather plug
D – Drain plug

L – Oil Level indicator
G – Grease Nipple

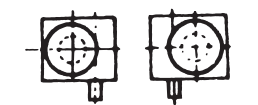
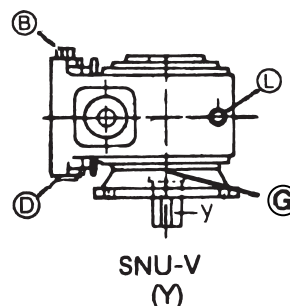
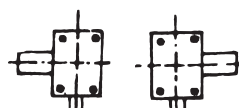
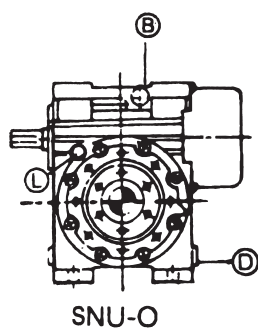
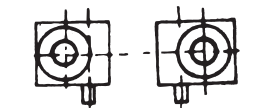
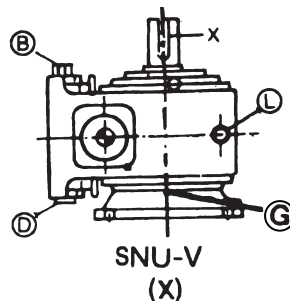
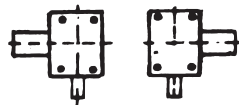
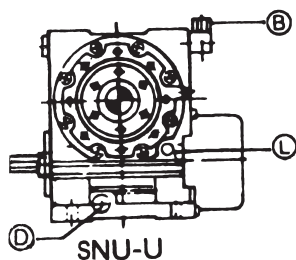

Replace **G** by plug for NU-V(X),V,(Y) in bottom side

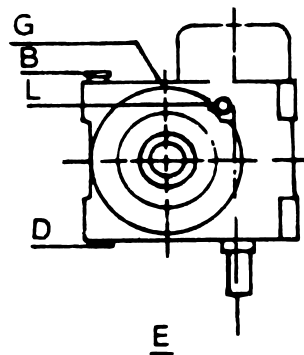
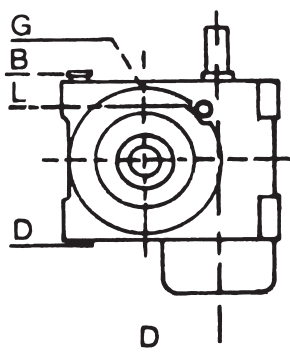
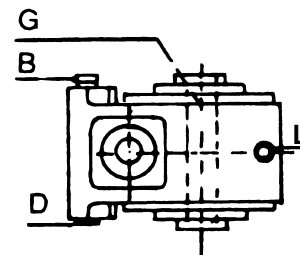
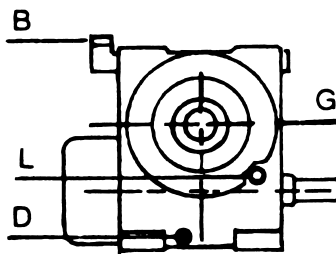
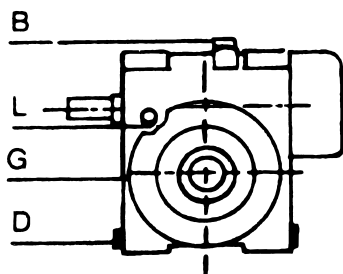



OPTIONAL STANDARD FEATURES

1. **SPRAG Holdbacks for Non-reversible Drives**

ELECON gear unit can be supplied, fitted with sprag holdback for non-reversible drives it is essential that the load or driven mechanism is prevented from running backwards after the driving motor is stripped e.g. inclined conveyors, elevator, winches etc.

The sprag holdback is incorporated on the fan end side of the high speed shaft. Visually and dimensionally the ELECON unit is unchanged. The hold back can be provided for either direction of rotation and the same should be specified when ordering.

2. **Base Frame**

Fabricated steel base frames are also supplied when requires.

3. **Steel Gearcases**

ELECON gear unit can be supplied with cast or fabricated steel cases for heavy duty application when loadings on the housings are in excess of the capacities of standard cast iron cases.

4. **Wormwheel construction**

Standard worm wheel comprise phosphorous bronze rims continuous welded to cast iron centres, where the duties demand rims are welded to steel centres.

5. **Slow speed shafts**

ELECON gear unit can be supplied with special slow speed shafts where required, These include units with special single extension, double extended shafts to the standard dimensions listed in this catalogue or special double ended extension. Additionally single or double ended shaft can be supplied in high tensile steel to heavy duty applications.



PRODUCT SAFETY INFORMATION

General

ELECON gear units will operate safely provided that they are selected, installed, used and maintained properly. As with any equipment consisting of rotating shafts and transmitting power, adequate guarding is necessary to eliminate the possibility of physical contact with rotating shafts or couplings.

Potential Hazards

The following points should be noted and brought to attention to the persons involved in the installation, use and maintenance of equipment.

1. For lifting of gear unit eye-bolts or lifting points (on larger units) should be used.
2. Check the grade and quantity of lubrication before commissioning. Read and carry out all instructions on lubricant plate and in the installation and maintenance manual literature.
3. Installation must be performed in accordance with the manufacturer's instruction and be undertaken by suitably qualified personnel.
4. Ensure the proper maintenance of gearboxes in operation. **USE ONLY ELECON SPARES FOR GEARBOXES.**
5. The oil level should be examined periodically, if required the oil should be filled again.
6. The operating speeds, transmitting powers, generated torques or the external loads must not exceed the design values.
7. The driving and the driven equipment must be correctly selected to ensure that the complete installation of the machinery will perform satisfactorily e.g. avoiding system critical speeds, system torsional vibration etc.

Any other required information or clarification can be obtained by writing to :

ELECON ENGINEERING CO. LTD.

POST BOX # 6, ANAND - SOJITRA ROAD, VALLABH VIDYANAGAR 388 120, GUJARAT, INDIA

As improvement in designing are continuously being made, the details and dimensions are subject to alteration without notice.